

SERIE

R

SHORT STROKE CYLINDERS

airtec.nl

CARATTERISTICHE TECNICHE - TECHNICAL CHARACTERISTICS

Pressione di esercizio <i>Working pressure</i>	1 ÷ 10 bar (doppio effetto - <i>double acting</i>) 2 ÷ 10 bar (semplice effetto - <i>single acting</i>)
Temperatura di esercizio <i>Working temperature</i>	0 ÷ +80 °C (-20 °C con aria secca - <i>with dry air</i>)
Versioni - Versions	semplice effetto (molla anteriore) - <i>single acting (front spring)</i> doppio effetto - <i>double acting</i>
Alesaggi - Bores	ø 8 - 12 - 20 - 32 - 50 - 63
Corse - Strokes	vedere tabelle corse standard - <i>see standard stroke tables</i>
Fluido - Fluid	aria compressa filtrata, non lubrificata - <i>compressed filtered, non lubricated air</i>

CARATTERISTICHE COSTRUTTIVE - CONSTRUCTIVE CHARACTERISTICS

①	Stelo - Rod	acciaio inox AISI 303 - <i>stainless steel AISI 303</i>
②	Guarnizione - Seal	poliuretano - <i>polyurethane</i>
③	Boccola - Bush	ø 8 - 12 - 20 ottone - <i>brass</i> ø 32 - 50 - 63 acciaio + PTFE - <i>steel+PTFE</i>
⑥	Testata - Cover	ø 8 - 12 - 20 ottone - <i>brass</i> ø 32 - 50 - 63 alluminio anodizzato - <i>anodized aluminium</i>
④	Boccola - Bush	acciaio+PTFE - <i>steel+PTFE</i>
⑤	O-ring	NBR
⑦	Tubo - Tube	alluminio anodizzato - <i>anodized aluminium</i>
⑧	Guarnizione - Seal	NBR
⑨	Pistone semplice effetto <i>Piston single acting</i>	ø 8 - 12 acciaio inox AISI 303 - <i>stainless steel AISI 303</i> ø 20 alluminio - <i>aluminium</i> ø 32 - 50 - 63 delrin - <i>delrin</i>
⑨	Pistone doppio effetto <i>Piston double acting</i>	Ø 12 - 20 alluminio - <i>aluminium</i> Ø 32 - 50 - 63 delrin - <i>delrin</i>
	Molla - Spring	acciaio - <i>steel</i>

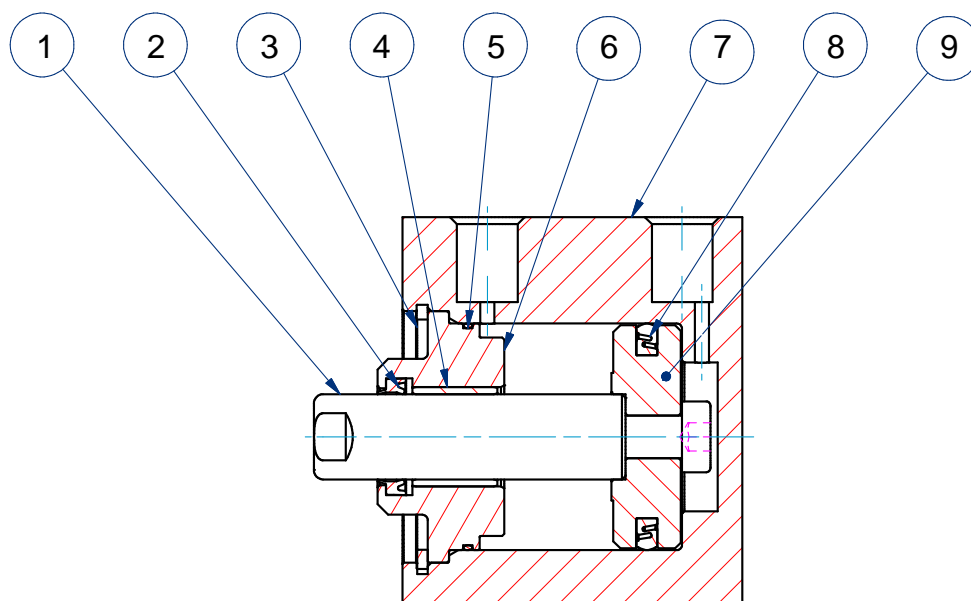

SERIE
R

CHIAVE DI CODIFICA

KEY CODE

R		D		0 1 2		. 0 1 0		. G S		. M	
				ALESAGGIO - BORE (Ø)		CORSA - STROKE (mm)				STELO - ROD	
				008 - 012 - 020 032 - 050 - 063		vedere tabelle corse std see std stroke tables				F femmina female	
				VERSIONE - VERSION						M maschio male	
				S semplice effetto molla anteriore single acting front spring						L liscio smooth	
				D doppio effetto double acting						GUARNIZIONI - SEALS	
				SERIE - SERIES						GS guarnizioni standard standard seals	
				R barra piena di alluminio aluminium solid bar							

SERIE

R

FORZE TEORICHE MINIME DELLE MOLLE

RS

THEORETICAL MINIMUM SPRING FORCES

	FORZA TRAZIONE [N] TRACTION FORCE [N]	FORZA DI BLOCCAGGIO [N] LOCKING FORCE [N]	CARICO MAX [g] MAX LOAD [g]
RS008.004.GS.L	3,2	25	-
RS012.004.GS.L	5	55	25
RS012.010.GS.L	7	53	25
RS020.004.GS.F	7	170	75
RS020.010.GS.F	15	160	75
RS020.025.GS.F	13	157	75
RS032.005.GS.F	28	454	100
RS032.010.GS.F	23	459	100
RS032.025.GS.F	21	461	100
RS050.010.GS.F	53	1080	200
RS050.025.GS.F	49	1075	200
RS063.010.GS.F	67	1765	250
RS063.025.GS.F	73	1735	250

FORZE TEORICHE DI TRAZIONE (P=6bar)

RD

THEORETICAL FORCES OF TRACTION (P=6bar)

	Ø	012	020	032	050	063	
RD	SPINTA THRUST	[N]	68	189	483	1.178	1.870
	TRAZIONE TRACTION	[N]	51	141	415	1.056	1.750

SEMPLICE EFFETTO - MOLLA ANTERIORE

RS

SINGLE ACTING - FRONT SPRING

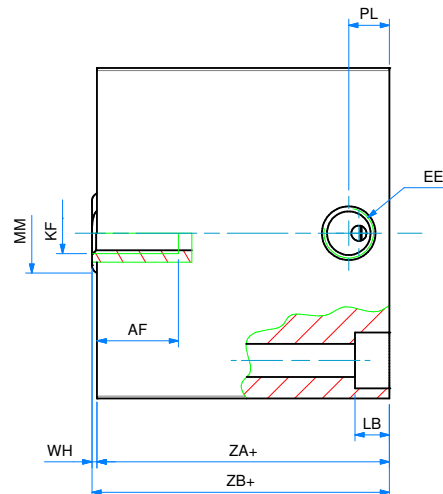
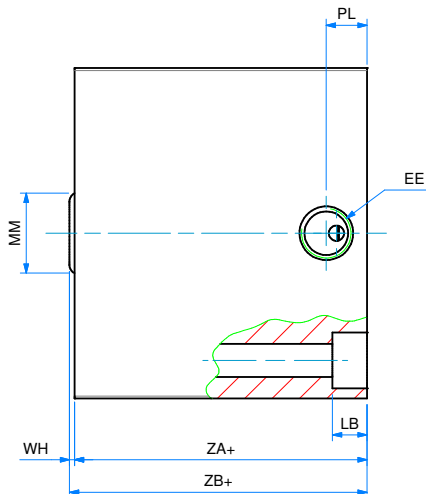
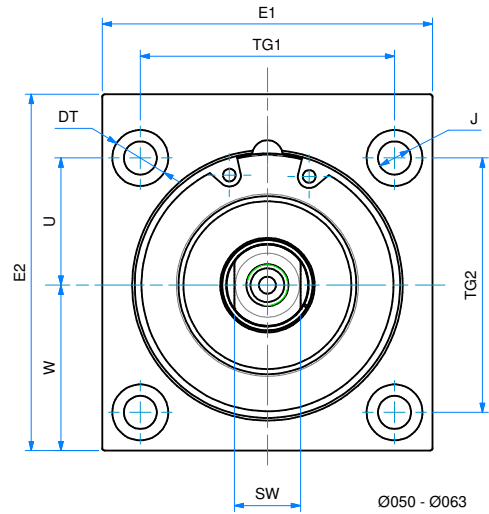
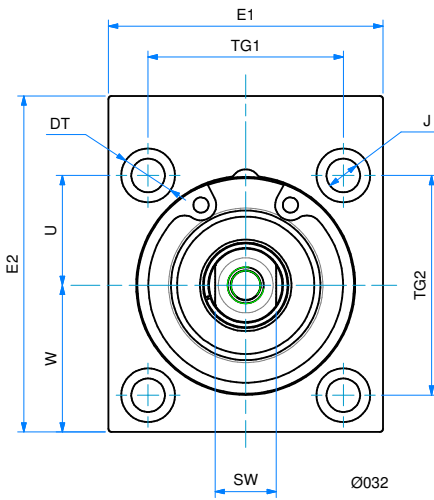
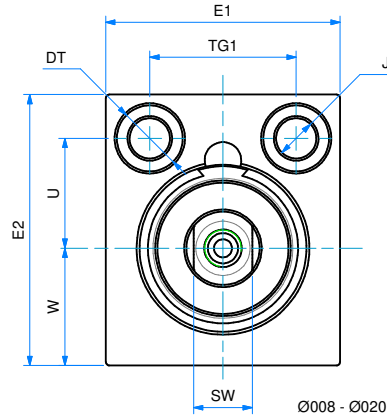
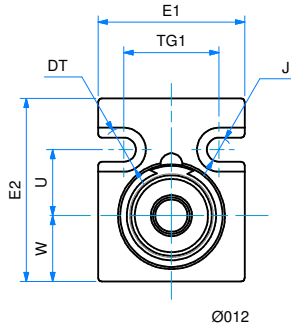
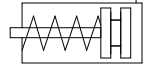

SERIE
R



SINGLE ACTING - FRONT SPRING

DIMENSIONI - DIMENSIONS							
COD.	RS008.004.GS.L	RS012.004.GS.L	RS012.010.GS.L	RS012.010.GS.F	RS020.004.GS.F	RS020.010.GS.F	RS020.025.GS.F
AF	-	-	-	10	9	10	10
ø DT	6	6	6	6	9	9	9
E1	18	20	20	20	32	32	32
E2	20	25	25	25	37	37	37
EE	M5	M5	M5	M5	M5	M5	M5
KF	-	-	-	M3	M5	M5	M5
LB	3,1	3,4	3,4	3,4	5,5	5,5	5,5
ø MM	4	5	5	5	10	10	10
ø J	3,4	3,3	3,3	3,3	5,5	5,5	5,5
PL1	5,5	6	6	6	5	5	5
SW	-	-	-	-	8	8	8
TG1	11	13	13	13	20	20	20
TG2	-	-	-	-	-	-	-
U	8	9	9	9	15	15	15
W	6,5	9	9	9	16	16	16
WH	1	1	4	4	1	1	1
ZA+	12	12	16	16	16	22	28
ZB+	13	13	20	20	17	23	29

DIMENSIONI - DIMENSIONS							
COD.	RS032.005.GS.F	RS032.010.GS.F	RS032.025.GS.F	RS050.010.GS.F	RS050.025.GS.F	RS063.010.GS.F	RS063.025.GS.F
AF	10	14,5	14,5	10,5	15,5	14,5	14,5
DT	8,8	8,8	8,8	11	11	14	14
E1	45	45	45	65	65	80	80
E2	55	55	55	70	70	85	85
EE	G1/8	G1/8	G1/8	G1/8	G1/8	G1/8	G1/8
KF	M6	M6	M6	M8	M8	M8	M8
LB	5,7	5,7	5,7	6,8	6,8	9	9
MM	12	12	12	16	16	16	16
ø J	5,5	5,5	5,5	6,5	6,5	9	9
PL1	8,5	8,5	8,5	7,5	8	8	8
SW	10	10	10	13	13	13	13
TG1	32	32	32	50	50	62	62
TG2	36	36	36	50	50	62	62
U	18	18	18	25	25	31	31
W	24	24	24	32,5	32,5	40	40
WH	1	1	1	1	1	1	2
ZA+	21	22	32,5	20	32,5	25	35,5
ZB+	22	23	33,5	21	33,5	26	37,5

+ = aggiungere lunghezza corsa (mm) - add stroke length (mm)

STELI STANDARD - STANDARD PISTON RODS						
ø	008	012	020	032	050	063
FEMMINA - FEMALE		X	X	X	X	X
MASCHIO - MALE						
LISCIO - SMOOTH	X	X				

ø	CORSE STANDARD - STANDARD STROKES
008	4
012	4 - 10
020	4 - 10 - 25
032	5 - 10 - 25
050	10 - 25
063	10 - 25

SERIE
R

DOPPIO EFFETTO

DOUBLE ACTING

RD

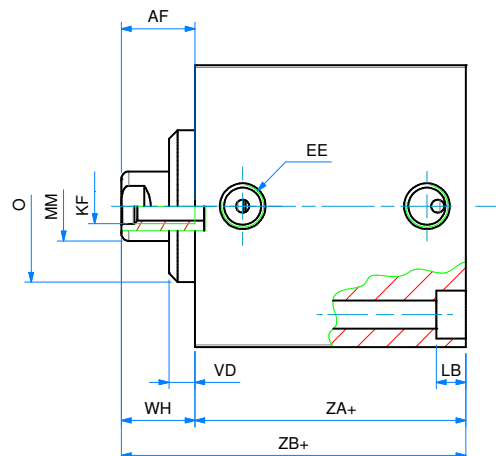
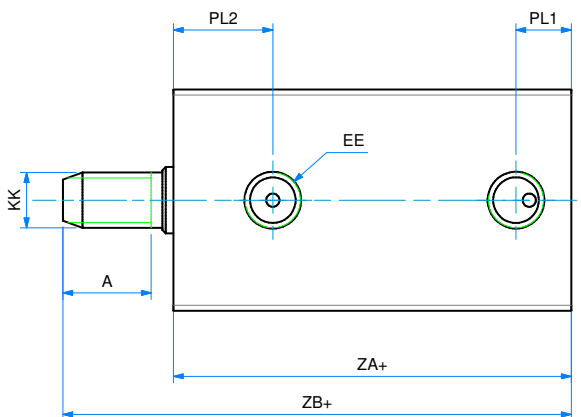
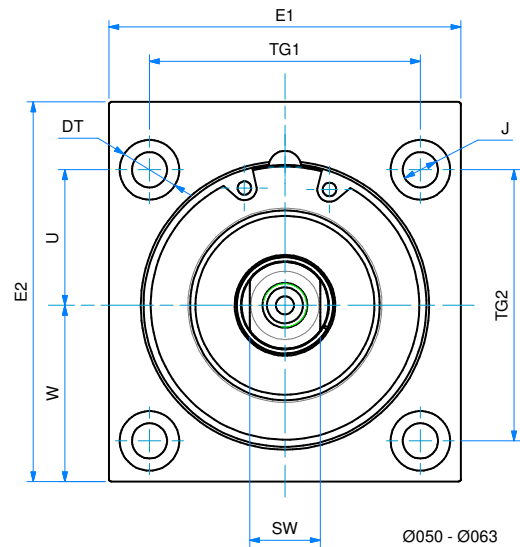
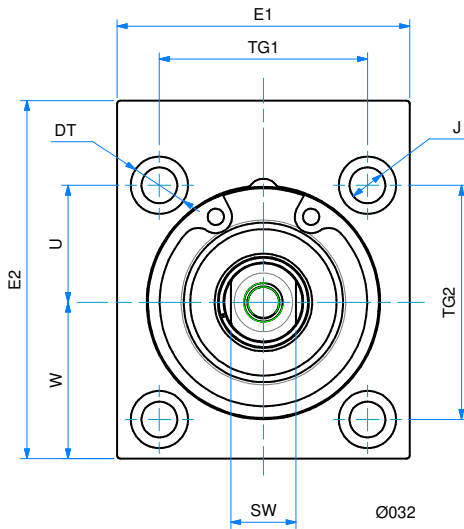
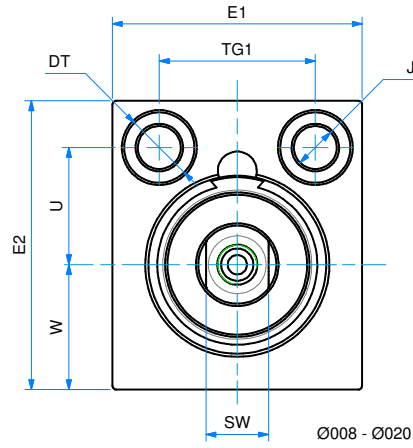
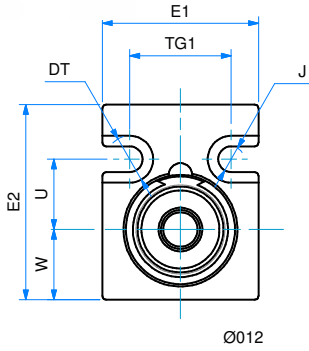
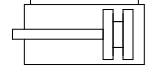

SERIE

R

DOUBLE ACTING

DIMENSIONI - DIMENSIONS					
Ø	012	020	032	050	063
A	9	-	-	-	
AF	-	10	15	17	17
Ø DT	6	9	9,5	11	14
E1	20	32	45	65	80
E2	25	37	56	70	85
EE	M5	M5	G1/8	G1/8	G1/8
KF	-	M5	M6	M8	M8
KK	M5	-	-	-	-
LB	3,4	5,5	5,7	6,8	9
Ø MM	6	10	12	16	16
Ø J	3,3	5,5	5,3	6,5	9
Ø O	-	-	22	35	35
PL1	5	5	8,5	9	8
PL2	9	8,5	12	11	13
SW	-	8	10	13	13
TG1	13	20	32	50	62
TG2	-	-	36	50	62
U	9	15	18	25	31
VD	-	-	3,5	6	6,5
W	9	16	24	32,5	40
WH	1	9,5	12,5	17	17
ZA+	21	24,5	33	32,5	35,5
ZB+	31	34	45,5	49,5	52,5

+ = aggiungere lunghezza corsa (mm) - add stroke length (mm)

STELI STANDARD - STANDARD PISTON RODS					
Ø	012	020	032	050	063
FEMMINA - FEMALE		X	X	X	X
MASCHIO - MALE	X				
LISCIO - SMOOTH					

Ø	CORSE STANDARD - STANDARD STROKES
012	5 - 10 - 15 - 20 - 25 - 30
020	5 - 10 - 15 - 20 - 25 - 30
032	5 - 10 - 15 - 20 - 25 - 30
050	5 - 10 - 15 - 20 - 25 - 30
063	5 - 10 - 15 - 20 - 25 - 30



